

# GREEN STAR

## Late Joiners' Package



709 Toronto Signals Army Cadets

Created 03 February 2016

Ref: A-CR-CCP-701/PF-001

## TABLE OF CONTENTS

INTRODUCTION	2
M103.01 RESPONSIBILITIES OF FOLLOWER	3
LEADERSHIP ACTIVITY	4
M106.01 – PARTS OF RIFLE	5
M106.02 – SAFETY PRECAUTIONS WITH AIR RIFLE	8
M106.03 – BASIC MARKSMANSHIP	9
M106.04 – RANGE COMMANDS	12
ACTIVITY	14
M107.02 – RANKS	15
ACTIVITY	17
M107.03 – PAYING OF COMPLIMENTS	18
M107.05 – WEARING CADET UNIFORM	20
M120.01 – ROLES OF THE CANADIAN FORCES	30
M121.01 – SELECT PERSONAL EQUIPMENT	33
M122.01 – TYPES OF MAPS	38
M122.02 – MARGINAL INFORMATION	38
M122.03 – CONTOUR LINES	41
ACTIVITY	42
M122.05 – GRID REFERENCES	43
ACTIVITY	46
ACTIVITY	47
NOTES	48
EVALUATIONS	52

## INTRODUCTION

This guide was created in order to give you the basic knowledge that you require as a Cadet while you start in the Red Star Program. The information contained has been deemed necessary information for you to be able to succeed as a Cadet. You will receive knowledge about Drill, Fundamentals, as well as Bushcraft. These skills will be enhanced as you progress through the Cadet program and will be evaluated as they are conducted. It is your responsibility to read through this guide, ask questions and once you are done you will be tested on the information you have learned.

### MISSION

The mission of the Cadet Program is to contribute to the development and preparation of youth for the transition to adulthood, enabling them to meet the challenges of modern society, through a dynamic, community-based program.

### VISION

The vision of the Cadet Program is a relevant, credible and proactive youth development organization, offering the program of choice for Canada's youth, preparing them to become the leaders of tomorrow through a set of fun, challenging, well organized and safe activities.

### AIMS

The aims of the Cadet Program are to:

- develop in youth the attributes of good citizenship and leadership;
- promote physical fitness; and
- stimulate the interest of youth in the sea, land and air activities of the Canadian Forces (CF).

### MOTTO

The motto of the Army Cadet Program is, "*Acer Acerpori.*" This is a Latin term which means "as the maple, so the sapling."

## **M 103.01 IDENTIFY RESPONSIBILITIES OF A FOLLOWER IN A TEAM**

In this section you will learn the responsibilities of being a follower. Cadets need to learn how to be effective members of a team. Understanding the responsibilities of a follower in a team setting will make cadets more aware of what is expected of them. This knowledge will enable them to contribute to the overall success of the team.

### **RESPECT THE LEADER AND OTHER TEAM MEMBERS**

The ability to work with other people in a team is a useful skill. A sincere respect for other people is a great asset. In order to be an effective team member one must respect what the leader is asking the team to do. It is also important to respect the opinion and views of the other members of the team.

### **COOPERATE WITH OTHERS**

In order for the team to effectively and efficiently achieve an objective the members must cooperate. Through cooperation a great deal more can be achieved than by working alone.

### **ADMIT MISTAKES AND LEARN FROM EXPERIENCE**

In a team setting one must be able to admit when they are wrong and learn from the mistake. This will make the team stronger and create a better outcome.

### **ACCEPT CONSTRUCTIVE CRITICISM**

Constructive criticism is observations or thoughts about ways to improve the manner in which a task was completed. Leaders will often provide constructive criticism to members of the team. This criticism is given to assist individuals develop as team member and eventually become leaders. Members must learn to take this criticism and use it in a beneficial way.

### **ASSUME RESPONSIBILITY**

Team members should be prepared to assume responsibility when needed. The team leader will often delegate duties to team members and rely on these members to be prepared and willing to take on the responsibility.

### **BE HONEST**

Team members must be honest with others in the team. Most people will believe and want to work with someone they trust. Honesty is an important characteristic of a good follower. In order to complete objectives, team members must trust each other and be honest.

### **ACCEPT OTHER TEAM MEMBERS FOR WHO THEY ARE**

It is important to be sensitive to other people's wants and needs and to changes in these wants and needs. Acceptance and understanding of individual differences will allow the group to communicate and cooperate.

### **KNOW THE JOB AND BE PREPARED**

A good follower needs to be knowledgeable about the group's goals. An effective follower should be organized and prepared.

### **COMMUNICATE CLEARLY WITH OTHERS**

A follower must be able to understand and communicate with the leader and other team members. Communication works in two directions, listening and speaking. The ability to listen to others is essential in receiving correct information and implementing the strategy outlined for the team.

**ACTIVITY – LEADERSHIP**

Unscramble the words and sentences

CERPTES HET DERLEA NDA EHORT AETM BESMERM

✂-----

RPCOEAEOT TWHI TERSOH

✂-----

IAMTD STSAKIEM DNA RLENA MFOR XRPEIECNEE

✂-----

PCETCA SRUCNTTIVEC IIISCTMRC

✂-----

SUSAME YEBPISONSILRIT

✂-----

EB TENHOS

✂-----

## M106 MARKSMANSHIP

### M106.01 PARTS AND CHARACTERISTICS OF DAISY AIR RIFLE

In this section you will learn about the Daisy Air Rifle. You will be expected to know the parts of the rifle in order for you to be familiar with it and competent to be able to shoot the rifle. There will be opportunities for you to shoot throughout the year. You will be expected to shoot the rifle at least once a year.

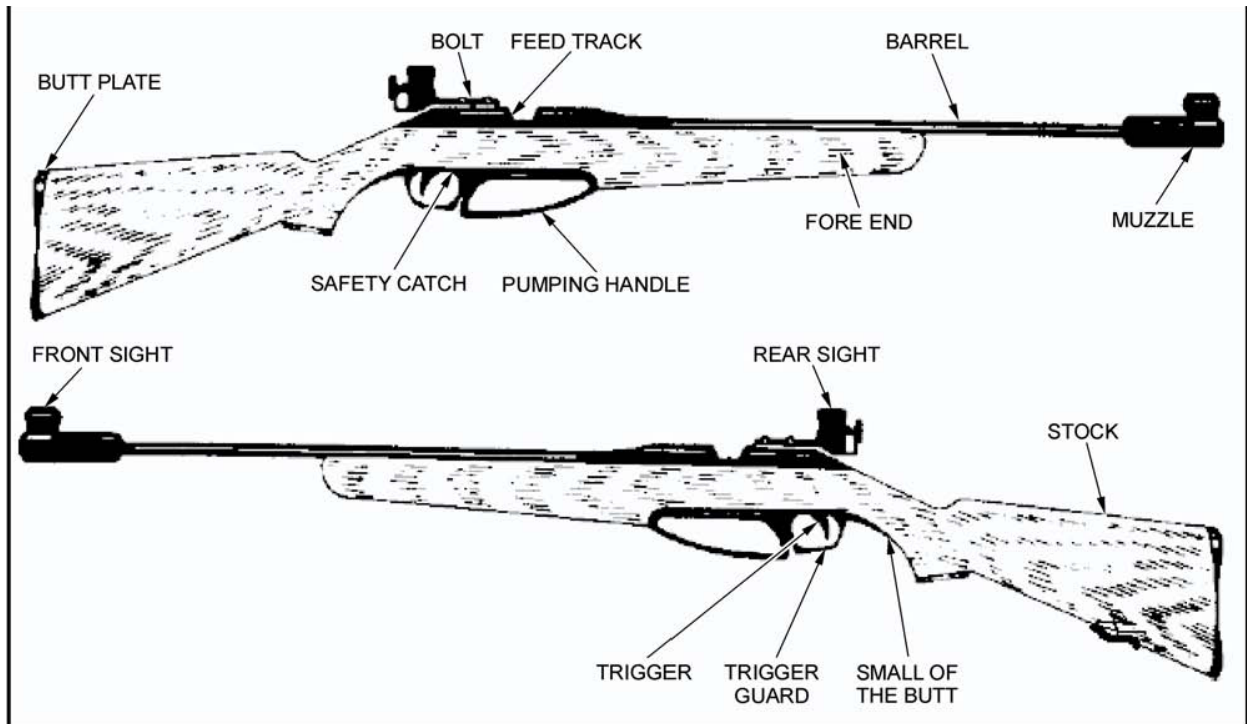

**Butt Plate (End of the Butt).** It is the part of the rifle directly in contact with the marksman's shoulder. When fitted properly, the butt plate aids in achieving a snug fit, and a consistent placement of the rifle into the shoulder. The addition of butt spacers allows for this adjustment in length.

**Spacers.** Plastic inserts that can be added or removed from the butt plate to vary its length. To add or take away butt spacers, use a Phillips screwdriver to loosen the butt plate and slide in/out the amount of spacers desired.

**Small of the Butt (Pistol Grip).** Curved area directly behind the trigger guard where the hand controlling the trigger grips the rifle.

**Stock.** Complete wooden portion of the rifle (from the butt plate end forward).

**Fore End (of the Stock).** Wooden portion of the stock from the trigger guard forward, in which the barrel and the rifle mechanism are encased.

**Sling.** It is a web sling made of nylon. Links the rifle to the marksman's arm to support most of the weight of the rifle. One end attaches to the sling bracket and the other to the upper arm.

**Sling Bracket (Hand Stop).** Adjustable metal clasp attached to the fore stock used to affix the sling to the rifle. It also acts as a hand stop, used to rest the left hand to prevent it from moving.

**Trigger.** Movable device that releases a spring and releases the rifle mechanism. This rifle has a single stage trigger that cannot be adjusted for weight.

**Trigger Guard.** Metal band that surrounds and protects the trigger.

**Safety Catch.** This is a mechanism that, once engaged, prevents the rifle from firing by locking the trigger in place. It is a cross bolt type device located on the trigger guard. The black side indicates that the rifle is unable to fire; the red side indicates the rifle is ready to fire. It should be ON (no red) at all times, unless firing.

**Bolt.** Metal lever used for opening or closing the rifle mechanism. It must be in the closed position in order to fire. For maximum safety when the rifle is uncased and not firing, the bolt should be kept open.

**Pump Handle.** Metal lever used to compress the air required to fire the pellet. Whenever the rifle is in a "safe rifle status", the pump lever should be left partially open.

**Front Sight.** Global front sight that uses aperture inserts.

**Rear Sight.** Micrometer sight adjustable for windage and elevation. It is easily attached to a metal rail located above the action. This rail allows for adjustment of the sight forward or backward, in order to maintain proper eye relief. The sight is attached using a small flat-blade screwdriver.

**Muzzle.** Front end of the barrel equipped with attachable barrel weight.

**Barrel With Barrel Weight.** Steel tube through which the pellet travels, extending from the muzzle to the chamber. The barrel weight ensures that the rifle's weight is evenly distributed and that the rifle's balance is maintained.

**Bore.** Interior of the barrel has spiral grooves cut into it. The lands are the ridges of metal between the grooves. Together, the grooves and lands are called rifling.

**Feed Track.** Delicate area where the pellet is inserted manually onto a single pellet adapter, or with a fiveshot clip.

**Single Shot Adapter.** Plastic clip that aids in placing a pellet in the chamber.

**Five-shot Clip.** Plastic clip that holds a maximum of five pellets and used to place the pellets in the chamber.

**Chamber.** Location where the pellet is held before firing.

**The characteristics of the Daisy 853C air rifle are:**

**Action.** Single pump pneumatic, straight pull-bolt.

**Total Length.** 97.8 cm.

**Total Weight.** 2.5 kg.

**Calibre.** 0.177 calibre (4.5 mm).

**Front Sight.** Global type with interchangeable aperture inserts.

**Rear Sight.** Fully adjustable peep rear sight with micrometer click adjustment.

## M106.02 SAFETY PRECAUTIONS FOR AN AIR RIFLE

### REMOVING A RIFLE FROM THE CASE

The rifle case should be clearly marked on the outside with an arrow, indicating in what direction the rifle inside is pointing. This will ensure that, when the case is opened, the rifle is pointing in a safe direction. The following steps must be followed when removing a rifle from its case:

1. Place the rifle case on a flat surface and ensure the arrow is pointing in a safe direction.
2. Open the case.
3. Cock the action (leave the bolt to the rear).
4. Confirm that the safety catch is ON.
5. Confirm that the pumping lever is partially open.
6. Slide the safety rod in the barrel towards the bolt until it can be seen in the feed track.
7. Remove the rifle from the case.
8. Remove the safety rod when you are on the firing line.

### SAFETY CATCH AND SECURITY MEASURES

The safety catch is a mechanism that, once engaged, prevents a rifle from firing by locking its trigger into place. It is located just in front of the trigger, on the trigger guard. To engage the safety catch (ON) it must be pushed towards the right **so no red can be seen**. To fire, the safety catch must be pushed towards the left in the OFF position and a red mark must be seen on it. For maximum security, it is recommended that the safety catch be kept engaged until the rifle is ready for firing.

### SAFETY ROD

To ensure that air rifles are not removed from the firing point or stored with a pellet in the chamber or barrel, a safety rod is to be inserted in the barrel from the muzzle end. It consists of two sections of doweling joined together in a "T" shape, and may be made of varying materials. The tip of the safety rod is to be coloured red so that it is visible in the feed track with the bolt fully to the rear.

### INDIVIDUAL SAFETY PRECAUTIONS

Upon receiving a rifle, or when the "Safe Rifle Status" is uncertain, individual safety precautions shall be done to confirm that the rifle is safe. An individual must ensure that:

1. The bolt is open fully to the rear;
2. The safety catch is in the ON position;
3. The pump lever is left partially open; and
4. A safety rod is placed in the barrel.

### SAFETY REGULATIONS

Safety regulations are all common sense and are easy to apply when people understand that they are necessary to help prevent accidents with the air rifle. Regulations include:

1. Treating the air rifle as if it is loaded;
2. Never pointing the air rifle at anyone;
3. Holding the rifle vertically when moving to and from the firing point;
4. Keeping fingers off the trigger until ready to fire;
5. Wearing safety glasses/goggles; and
6. Employing hygiene on the range by washing hands after every practice.



## M106.03 BASIC MARKSMANSHIP TECHNIQUES

### GOOD POSITIONING

Obtaining a good prone position is one of the most, if not the most, important principle of marksmanship. A good prone position helps to maintain comfort and stability during the firing session. The prone position is assumed when the shooter lies flat, directly behind the rifle, with a very slight angle between their body and the rifle, and in line with the target. The position should be:

- natural;
- without strain;
- comfortable; and
- stable, in that the:
  - body should form an angle with the line of sight;
  - spine should remain straight;
  - left leg should be parallel with the spine;
  - right foot should turn out and point to the right;
  - left foot should either be straight or point towards the right; and
  - right knee should form an angle with the left leg.

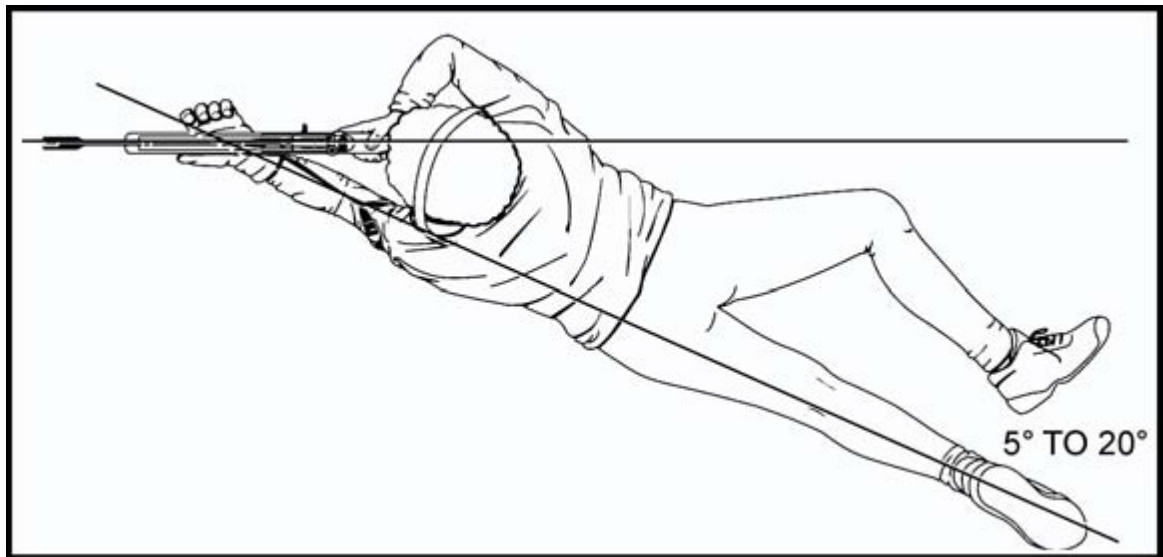

### HOLDING THE AIR RIFLE

The prone position allows holding to be achieved with as little movement and muscular tension as possible, in that the:

- left elbow should be positioned slightly to the left of the rifle;
- left hand must rest firmly against the sling swivel, and the fingers should be relaxed and not grip the fore end;
- right hand should slightly grip the small of the butt with constant pressure;
- right thumb should be placed on the stock directly behind the rear sight or around the small of the butt;
- right elbow should rest naturally where it falls, not too close or too far from the rifle;
- the shoulders should be straight and form right angles with the spine;
- the butt plate is kept firmly in the hollow of the right shoulder. The right elbow will naturally fall in the same spot throughout the relay; and
- the head rests comfortably on the butt and remains straight.

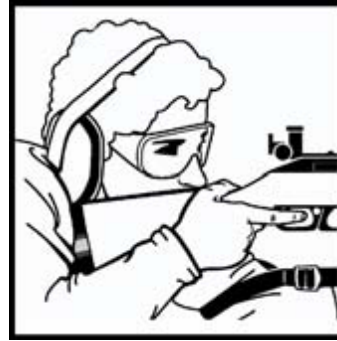

### AIMING THE AIR RIFLE

Cadets must constantly strive to maintain proper sight alignment, while obtaining a sight picture. It is the most critical element of the aiming process.

The **aiming process** consists of:

- adopting a comfortable position; and
- ensuring proper body alignment with the target.

**Sight Alignment.** It is the alignment of the eye, the rear sight, and the front sight. When cadets bring their eye 5 to 15 cm from the rear sight, they will find that the small hole is large enough to look through and see all of the front sight. Proper sight alignment is a matter of centering the front sight tube in the rear sight. The tube will not quite fill the rear sight and cadets will be able to see light around the outside of the tube; we call this a “line of white”.

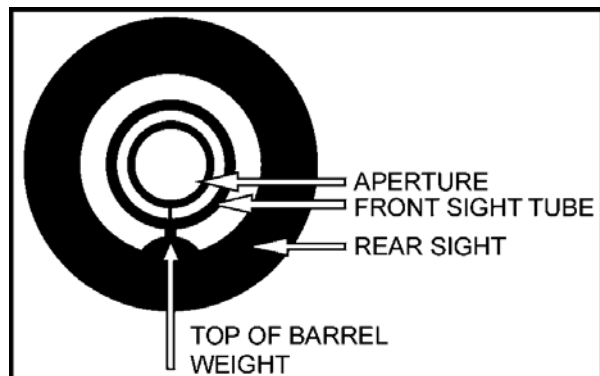
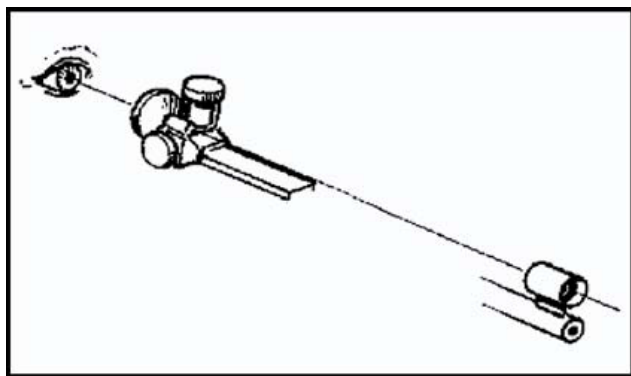

**Sight Picture.** To obtain a proper sight picture, a bull’s-eye is simply added to the innermost ring. The goal during the aiming process is to maintain proper sight alignment while keeping the bull centered in the front sight.

### LOADING THE AIR RIFLE

1. Pick up the rifle with the left hand.
2. Ensure the safety catch is in the ON position.
3. Pump the air rifle, pausing for 3 seconds.
4. Bring the pump handle back to closed position.
5. Simulate loading a pellet, or load an auto indexing five-pellet clip into the feed track.
6. Close the bolt.

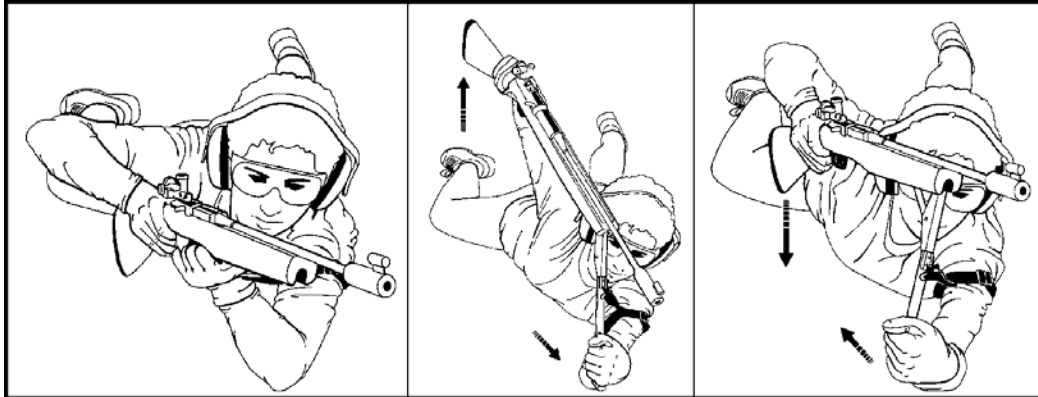

### UNLOADING THE CADET AIR RIFLE

Follow the unloading sequence of the cadet air rifle:

THE RSO (range safety officer) WILL CALL OUT “UNLOAD”

1. Pick up the air rifle.
2. Remove five-pellet clip (if used).
3. Open the bolt (do not insert a pellet).
4. Pump the air rifle, pausing for 3 seconds.
5. Close the bolt (do not insert a pellet).
6. Place the safety catch in the OFF position.
7. Aim the rifle at the target.
8. Squeeze the trigger.
9. Place the safety catch in the ON position.

THE RSO WILL CALL OUT “PREPARE FOR INSPECTION”

1. Open the bolt.
2. Open the pump handle slightly.
3. Place the rifle on shoulder, muzzle pointed down range.
4. Wait to be cleared by the RSO.
5. Lay the rifle down.

### FIRING THE CADET AIR RIFLE

Follow the sequence required to fire the cadet air rifle, to include:

1. When the RSO gives the command, place safety catch in the OFF position.
2. Aim the air rifle at the target.
3. Squeeze the trigger.
4. Open the bolt, pump the rifle, reload, aim and fire.
5. Repeat the last step until firing is complete.
6. Upon completion, place the safety catch in the ON position and partially opening the pump lever.
7. Lay the air rifle down.

**M106.04 FOLLOW THE RULES AND COMMANDS ON THE AIR RIFLE RANGE**

Range Standing Orders are locally produced for each range. They detail rules to be followed on that range. General rules observed on all ranges include:

1. Rifles will be proved safe when picked up, handed to or received from another person.
2. Rifles are never pointed at any person.
3. Safety rods shall be inserted into the barrels of rifles when not in use on the range.
4. Horseplay is forbidden on the range.
5. Rifles, whether loaded or not, will always be pointed down range.
6. Eating is not permitted on or near the range or around the pellets.
7. All personnel shall read or be briefed on the contents of the Range Standing Orders.
8. The RSO's directions and orders are to be obeyed at all times.

**RANGE COMMANDS AND WHAT TO DO**

<b>Command</b>	<b>Action To Be Taken</b>
1. "Cover off your firing point"	Move to a position behind your assigned firing point.
2. "Place your equipment down and stand back"	As directed.
3. "Adopt the prone position"	Lay down in prone position IAW EO M106.03 (Section 3).
4. "G.R.I.T." in that GRIT is the acronym for: a. Group (relay) b. Range c. Indication d. Type	Listen for direction on type of shooting to be carried out.
5. "Relay: load, commence firing"	Load IAW EO M106.03 (Section 3), and fire.
6. "Relay, cease fire."	Stop, engage the safety catch of the air rifle, and wait for directions.
7. "Relay, resume fire"	As directed.
8. "Relay, unload"	Unload IAW EO M106.03 (Section 3).
9. "Relay, prepare for inspection"	Prepare for inspection IAW EO M106.03 (Section 3).
10. "Relay, stand up"	As directed
11. "Change targets; and change relay."	Move forward under direction of RSO, retrieve target and replace with new one, move back off of range.

ACTIVITY – LABEL PARTS OF RIFLE

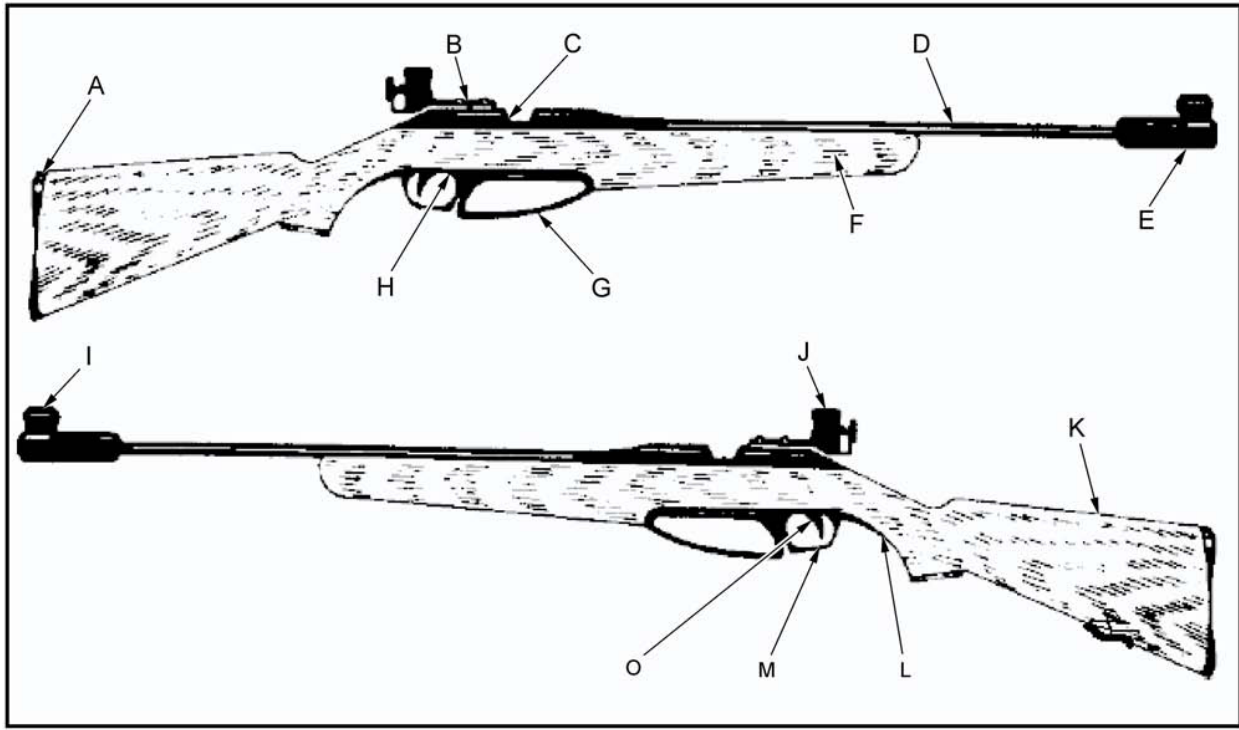

Put the letter next to the matching name of the part of the cadet air rifle.

1. Feed Track \_\_\_\_\_
2. Small of the Butt \_\_\_\_\_
3. Barrel \_\_\_\_\_
4. Fore End \_\_\_\_\_
5. Rear Sight \_\_\_\_\_
6. Trigger \_\_\_\_\_
7. Bolt \_\_\_\_\_

8. Safety Catch \_\_\_\_\_
9. Muzzle \_\_\_\_\_
10. Pump Lever \_\_\_\_\_
11. Front Sight \_\_\_\_\_
12. Trigger Guard \_\_\_\_\_
13. Butt Plate \_\_\_\_\_
14. Stock \_\_\_\_\_

## M107 SERVE IN AN ARMY CADET CORPS

### M107.02 CADET AND OFFICER RANKS

#### CADET RANKS NON-COMMISSIONED MEMBERS (NCMS)

Rank is a system of grading seniority and command within military organizations. The gold arrows are referred to as “chevrons”. The more chevrons used, the higher the seniority of the individual. These chevrons are worn on the upper arm, on the right sleeve of the cadet tunic.



PRIVATE (TRAINED)  
(PTE T)



CORPORAL  
(CPL)



MASTER CORPORAL  
(MCPL)



SERGEANT  
(SGT)

The “Tudor” crown represents the rank of Warrant Officer (WO).

The “Tudor” crown surrounded by a laurel wreath represents the rank of Master Warrant Officer (MWO).

The Canadian Coat of Arms represents the rank of Chief Warrant Officer (CWO).

These ranks are worn low on the sleeve of the right arm of the cadet tunic.



WARRANT OFFICER  
(WO)



MASTER WARRANT OFFICER  
(MWO)



CHIEF WARRANT OFFICER  
(CWO)

## COMMISSIONED OFFICERS RANKS

Officers of the CF wear their ranks low on the sleeve of the tunic. The rank insignias consist of pips, crowns and crossed sabres and batons. Officers also wear slip-ons or shoulder boards (Navy) on the epaulettes on their shoulders when wearing shirts, sweaters and jackets. When in field clothing, CADPAT, the rank is worn in the centre of the chest.

### SUBORDINATE AND JUNIOR OFFICERS

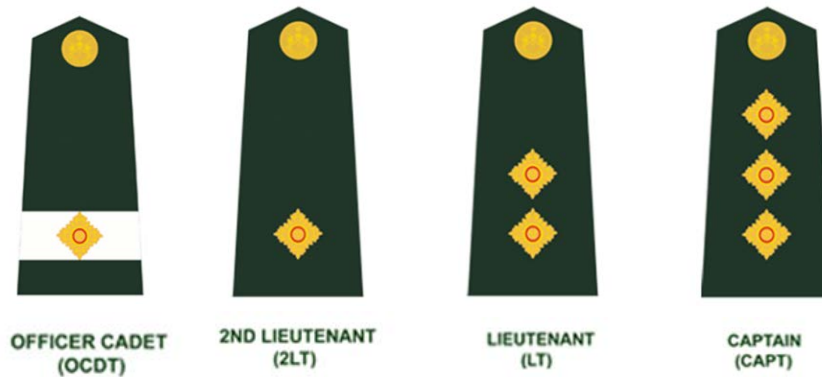

### SENIOR OFFICERS



### GENERALS



ACTIVITY

NAME THE RANKS





## **M107.03 PAYING OF COMPLIMENTS**

### **ADDRESSING CADET NCOs AND SUBORDINATE OFFICERS**

It is important to pay the correct compliments to the appropriate individuals. When addressing a cadet NCO or a subordinate officer, the cadet will stand at the position of attention. As cadet NCOs and subordinate officers do not hold a commission from the Queen, they are not saluted. Throughout the conversation, the cadet shall address the NCO or subordinate officer by their rank and surname and remain at the position of attention. When the cadet has completed addressing the NCO or officer, they should dismiss themselves appropriately by turning to the right.

### **ADDRESSING COMMISSIONED OFFICERS**

When addressing commissioned officers, the same procedures are followed as when addressing NCOs and subordinate officers except a salute shall be given. The cadet shall stand at the position of attention after approaching the commissioned officer. The cadet will then give the appropriate salute as outlined in A-PD-201-000/PT-000, *Canadian Forces Manual of Drill and Ceremonial*. Throughout the conversation the cadet shall address the commissioned officer by their rank and surname and always remain at the position of attention unless otherwise directed by the commissioned officer. When the cadet has completed addressing the officer, they should again salute and dismiss themselves appropriately.

### **PAYING COMPLIMENTS INSIDE A BUILDING**

Salutes are not given inside buildings except when on parade, during ceremonial occasions, or when entering and leaving offices. However, cadets shall turn their head and offer a polite greeting when meeting an officer in a common area. It is not customary to wear headdress inside a building.

### **ENTERING AN OFFICE**

When entering an office the cadet shall:

- stand at the position of attention in the doorway;
- salute if wearing headdress and the office occupant holds a commission; and
- politely ask permission to enter the office.

### **LEAVING AN OFFICE**

When leaving an office the cadet shall:

- stand at the position of attention in the doorway;
- salute if wearing headdress and the office occupant holds a commission; and
- depart.

### **OTHER OCCASIONS TO PAY COMPLIMENTS**

It is appropriate for cadets to salute on different occasions:

- When the Canadian or another foreign national anthem is played.
- When recognizing a commissioned officer who is not in uniform.
- When The National Flag of Canada is being lowered or raised.
- When boarding or disembarking any of Her Majesty's Canadian ships or those of a foreign service, cadets shall pay compliments to the quarterdeck.

## QUESTIONS

Answer the following Questions

Q1. Are you required to salute commissioned officers? Why?

Q2. When should the commissioned officer be saluted?

Q3. Name two times or places where compliments are paid inside a building.

Q4. Does one salute when recognizing a commissioned officer out of uniform?

Q5. Does one pay compliments if the Star Spangled Banner is played?

## M107.05 WEARING THE CADET UNIFORM

### OCCASIONS TO WEAR THE UNIFORM

The Army Cadet uniform must be worn when:

- Attending training or proceeding to or from a place of training unless the corps CO gives directives to the contrary.
- Proceeding to or from a CSTC (Cadet Summer Training Center)
- Attending ceremonies or functions at which the wearing of the uniform is appropriate and authorized by the CO of the corps or CSTC.

### RESPONSIBILITY FOR THE ARMY CADET UNIFORM

When given an Army Cadet uniform:

- all cadets are responsible for its care, cleaning, custody and return at the end of cadet service;
- replacement of worn uniform parts shall be at public expense where reasonable care has been taken with the uniform;
- issued uniform parts shall not be altered or modified to obtain a reasonable fit; and
- badges shall be sewn on the uniform neatly using thread that blends with the badge and uniform. Badges shall not be glued.

### GENERAL APPEARANCE OF THE UNIFORM

In caring for the cadet uniform, the cadet shall:

- ensure it is free from lint and dirt;
- polish metal pieces where applicable;
- ensure the badges are properly affixed to the uniform using thread that blends with the badge and uniform;
- clip any loose threads that may appear; and
- perform any routine maintenance that may be required to keep the uniform sharp and in good repair.

### CADET BERET

The Army Cadet beret shall be worn as follows:

- the beret is placed evenly on the head with the sweat-band 2.5 cm above the eyebrows;
- the badge is centred over the left eye;
- the crown of the beret is pulled downward to the right and rear; and
- drawstrings are tacked inside the gap of the sweat-band.

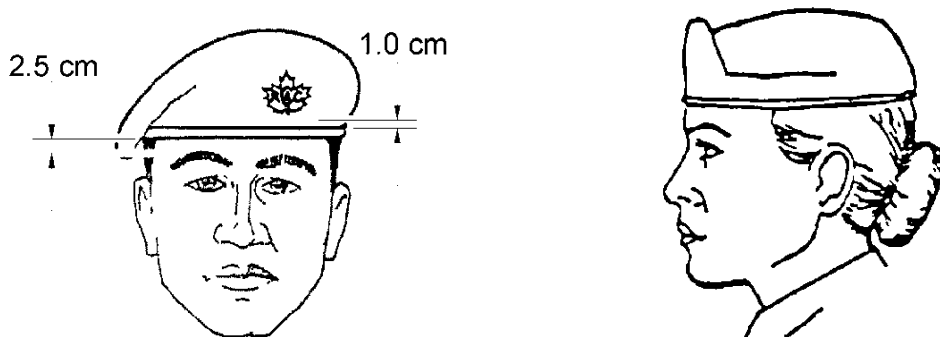

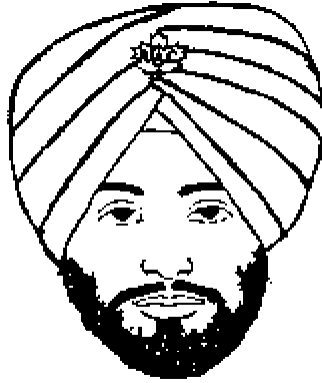

### **BERET INSIGNIA**

Insignia shall be worn on the beret centred on the built-in back plate with the base of the badge 1 cm above the band. For highland dress, the badge can be centred on the built-in back plate of the left side of the Glengarry, Balmoral or Caubeen.

Royal Canadian Army Cadet Dress Instructions Care of the beret includes:

- ensuring that it is free from lint and dirt;
- polishing the badge when required; and
- washing the leather sweat-band when required.

### **WIDE BRIMMED TAN SUMMER HAT**

The wide brimmed tan summer hat may be worn during summer activities for which the beret is not suitable, in order to protect the skin and eyes from the sun.

### **TOQUE**

The toque may be worn outside when weather conditions dictate.

### **INSIGNIA**

**Insignia, Shoulder Title RCAC or Insignia, Affiliated Unit.** Shall be worn on both sleeves of the cadet jacket.



**Insignia, Cadet, Maple Leaf.** Shall be worn on both sleeves of all authorized cadet uniform jackets, except the combat uniform jacket worn by staff cadets at a CSTC. Must be worn on the left breast of the all-season jacket.

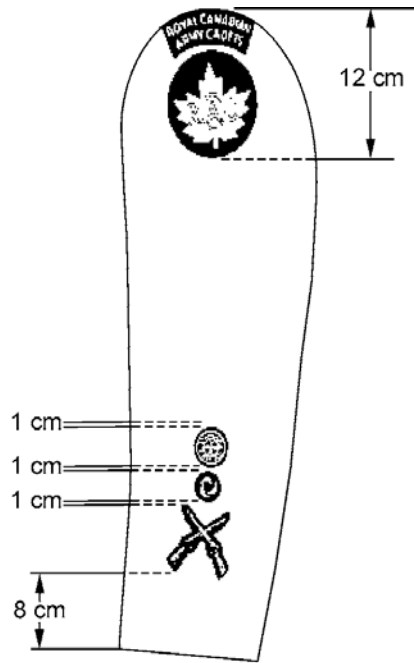

**Cadet Slip-on.** Shall be worn with the short sleeve orders of dress and overcoats at cadet corps and by staff cadets on all orders of dress at CSTC.

**Cadet Armlet.** May be worn (at the discretion of the CO) by staff cadets holding training appointments at a CSTC. The armlet shall contain the RCAC shoulder title badge and the appropriate acting rank badge.

### SHIRTS

**Shirt, Cadet, Short Sleeve.** May be worn with tie, ascot or open neck, with or without jacket. Rank slip-ons shall be worn with the short sleeve shirt.

**Undershirt.** The olive green cotton T-shirt may be worn with the appropriate orders of dress.

**Grey Sports T-shirt.** Shall be worn tucked inside the sports shorts during physical activities.

**White Undershirt.** Cotton shirt which may be worn with any order of dress. The undershirt shall not be visible at the neck opening.

### SWEATER AND JACKETS

**Sweater, Turtleneck, Long Sleeve.** Sweaters may be worn with or without the jacket, but the jacket shall be worn when going to and from the corps location. Sleeves shall not be rolled or pushed up the arm.

**Uniform Jacket.** The jacket shall be worn fully buttoned except the top button. Sleeves shall be rolled pressed with no creases. Jackets may be removed in buildings and offices when authorized.

**Jacket Belt.** Shall be worn so as the excess of the belt, once attached, is on the same side as the buttonhole flap. The buckle shall be adjusted so that the excess of the belt is not more than 8 cm.

**All-season Jacket.** May be worn year round when weather conditions dictate. RCAC crest must be worn on the left breast of the all-season jacket. The liner and the exterior jacket may be worn separately or as a set. Rank slip-ons shall be worn on both. Medals, ribbons and sashes may be worn on the all-season jacket for outdoor parades.

**ACCESSORIES**

**Necktie.** Shall be knotted neatly using a Windsor or four-in-hand knot and shall be kept tight. When the jacket is removed, the tie shall not be tucked into the shirt, unless for safety reasons.



Windsor knot



Four-in-hand knot

**Nametag.** Can be obtained locally. The standard cadet name tag shall be detachable, made of black and white laminated plastic plate 6.3 cm in length and 1.2 cm in height, inscribed with white lettering 0.6 cm high, and shall indicate the surname of the cadet only.

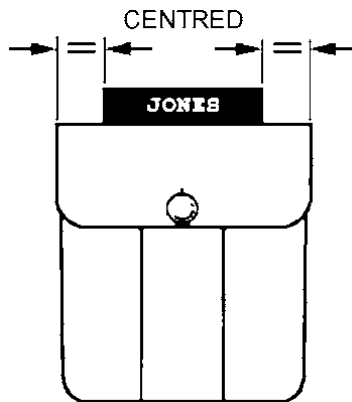

**Sash.** Cadet CWO's, MWO's, WO's and Sgt's are authorized to wear a sash, provided it respects the affiliated unit's dress regulations. Army sashes are crimson or scarlet depending on the rank. The sash is a parade accessory that can be worn at the local unit. The sash is only authorized at CSTC's or when on exchanges on the authority of the CO.

**Black Wool Gloves.** May be worn when weather dictates, or shall be worn when ordered.

**Black Mitts.** Plain black civilian pattern mitts may be worn with the overcoat, parka or all-season jacket during winter dress periods and when weather conditions dictate.

## TROUSERS/BELT/SHORTS

**Trousers.** Will be pressed without starch so as to have creases down the centre of each leg. Creases shall extend from the top of the leg to the bottom. The length of the trousers should extend to the third eyelet of the ankle boot.

**Trousers/Slacks Belt.** The trousers/slacks shall be worn with a black belt. The CO may authorize the RCAC belt buckle.

**Grey Sport Shorts.** Shall be worn at the waist, and must not allow for the underwear to be visible.

## FOOTWEAR

**Grey Wool Socks.** Shall be worn with boots and running shoes. If a cadet suffers from a recognized allergy to wool, grey or black cotton or nylon socks may be worn.

**Running Shoes.** Shall be worn as directed by the cadet corps or the CSTC CO.

**Boots.** Shall be laced across horizontally from side to side. Boots shall not be modified by any type of metal cleats, hobnails or other metal attachments to the heel or sole. No varnish other than shoe polish can be used to shine the boots.



Boots should be cared for by:

- cleaning the welts with an old toothbrush and black boot polish;
- using a soft cloth wrapped around the index finger, ensuring it is flat against the pad of the finger without any wrinkles;
- dampening the end of the cloth and applying a small amount of neutral then black boot polish
- applying the polish to the boot in a steady, light circular motion, starting with larger circles to cover the area of the boot and using smaller circles, continuously working the polish into the boot;
- continuing to rub polish with a circular motion until the circles can no longer be seen; and
- breathing on the boot often to help work the polish into the boot.

## GENERAL APPEARANCE

Cadets in uniform shall be well groomed with footwear cleaned and shined. The uniform shall be clean and properly pressed at all times. In particular, buttons, fasteners and zippers shall be kept closed. Pockets shall not be bulged; items such as glasses, sunglasses, glasses cases, pens, pencils, key-rings or paper shall not be visibly extended nor protrude from pockets or be suspended from waist belts or pockets.

## HAIRSTYLES

Hair on the head shall be neatly groomed and conservatively styled. The length, bulk and style of hair shall not preclude the proper wear of the beret. In particular, style and colour shall not be bizarre, bleached, exaggerated or unusual in appearance. Unusual colours such as green, bright red, orange, purple, etc., are not permitted. Hair must be secured or styled back to reveal the face and any accessories used to secure or control hairstyles shall be as unobtrusive as possible. Hair ornaments shall not be worn, except for female cadets conservative barrettes, which are to blend with the hair colour.

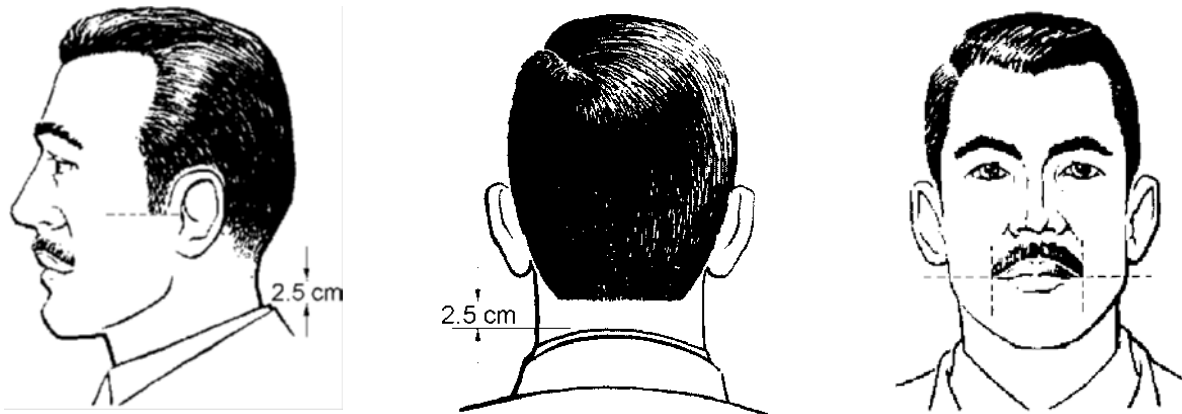

**Male Hairstyles.** Male cadets' hair shall be taper trimmed at the back, sides, and above the ears to blend with the hairstyle. It shall be no more than 15 cm in length and sufficiently short that, when the hair is groomed and beret is removed, no hair shall touch the ears or fall below the top of the eyebrows.

**Sideburns.** Sideburns shall not extend below a line horizontally bisecting the ear, and shall be squared off horizontally at the bottom edge and taper trimmed to conform to the overall hairstyle.

**Moustaches.** When moustaches are worn, the unshaven portion of the face shall not extend outwards beyond the corners of the mouth. Moustaches should be kept neatly trimmed, not greater than 2 cm in bulk, not to extend below the corners of the mouth and not protrude beyond the width of the mouth.

**Beards.** Beards shall not be worn except for those cadets who are adherents of the Sikh religion, or cadets with recognized medical problems preventing them from shaving. In the latter case, a note from a medical practitioner is required.



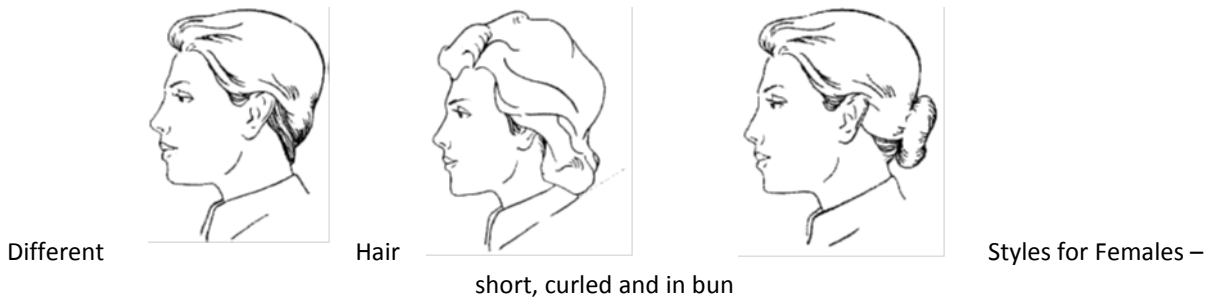

**Female Hairstyles.** Hair shall not extend below the edge of the shirt collar. Exaggerated styles, including those with excessive fullness or extreme height, are not authorized.

**Braids.** Shall be styled conservatively and tied tightly, secured at the end by a knot or a small-unadorned fastener. A single braid shall be worn in the centre of the back. Double braids shall be worn behind the shoulders. Hair shall be a maximum length, when gathered behind the head and braided, which does not extend below the top of the armpit.



Multiple braids and/or cornrows shall be directed to the back of the head, pulled tight to the head and secured at the end by a knot or a small-unadorned fastener. Multiple braids extending below the edge of the collar are to be gathered in a bun. Hairpieces and extensions are not permitted.

**MAKE-UP**

Females are permitted to wear a minimal amount of make-up. When wearing the uniform, make-up shall be applied conservatively. There are to be no false eyelashes, heavy eyeliner, brightly coloured eye shadow or lipstick, coloured nail polish or excessive facial make-up.

**JEWELLERY**

The only jewellery that may be worn in uniform shall be a wristwatch (conservative in design and colour), a medical alert bracelet, and a maximum of two rings which are not of costume jewellery nature. Female cadets in uniform may wear a single pair of plain gold, silver stud or white pearl earrings in pierced ears. The single stud earring, worn in the centre of each earlobe, shall be spherical in shape and not exceed 0.6 cm in diameter. Male cadets are not authorized to wear an earring or earrings. Only a single earring or healing device, worn in the centre of each earlobe, may be worn at a time.

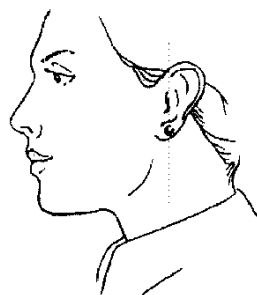

Placement of earring

### TATTOOS AND BODY PIERCING

Cadets shall not acquire visible tattoos that could be deemed as offensive or otherwise reflect discredit on the CCO. Cadets in uniform shall not wear visible body piercing adornments (tongue included). Use of an adhesive bandage for the purpose of covering a piercing is **not** authorized.

### UNDERGARMENTS

Undergarments including brassieres for female cadets, shall be worn under all numbered orders of dress and shall be of an appropriate colour so as not to be visible through uniform items of clothing. Males shall also wear an undergarment under the highland order of dress.

### EYEGASSES/SUNGLASSES

Eyeglasses and sunglasses shall be conservative in design and colour. Sunglasses with photo chromic or mirrored lenses are not authorized for wear. Cadets who normally wear eyeglasses may wear either conventionally framed prescription sunglasses, or conservatively styled clip-on sunglasses when conditions and circumstances dictate. Other cadets may wear conservatively styled sunglasses, which do not detract from the overall appearance of the uniform when conditions and circumstances dictate. Sunglasses shall not be worn on parade day unless authorized by the cadet corps or CSTC CO in special circumstances.

### OTHER

**Civilian Clothing.** Civilian clothing, other than those specific items listed in CATO 46-01 shall not be worn with the cadet uniform unless authorized by the cadet corps or CSTC CO in special circumstances. This includes but is not limited to civilian jackets and hats.

**Backpacks.** Civilian pattern backpacks of conservative appearance may either be carried in the left hand or worn suspended from both shoulders and square on the back. No item will be suspended from the backpack and straps and straps shall not be left loose.

**Purse.** (Female cadets only) The purse must be black and conservative in nature, and held in the left hand or suspended over the left forearm. When the purse is carried as a shoulder bag, the strap shall be suspended from the left shoulder with the top of the purse not higher than waist level. The purse shall not be carried as a shoulder bag with the strap shortened to handbag length.

**Carrying of Articles.** If any one article is carried, such as a briefcase, umbrella or raincoat, it shall be carried in the left hand. If an article is carried when marching, the left arm is not swung.

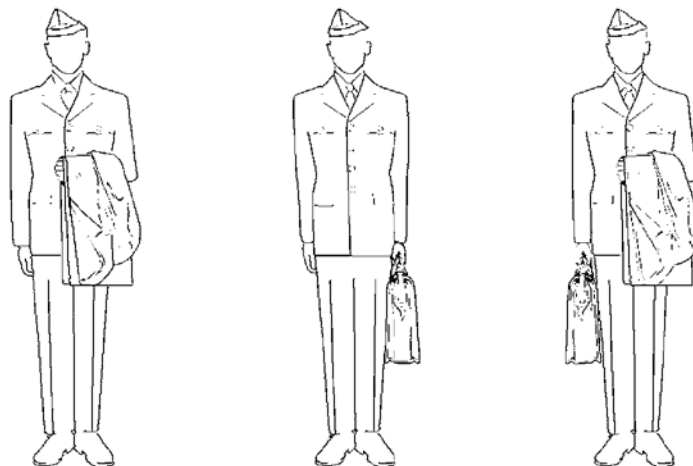

## ORDERS OF DRESS

There are different orders of dress to be worn dependent on weather, and what the CO determines as appropriate dress. CO parades and civilian parades generally require full dress uniform, unless otherwise stated by the CO.



Full dress



Short sleeve/summer dress



Winter dress with turtle neck



PT dress

## QUESTIONS

ANSWER THE FOLLOWING QUESTIONS

Q1. True or false.....Cadets have to wear their uniform when proceeding to and from a CSTC?

Q2. Are cadets responsible for paying for their uniforms?

Q3. True or false: Badges shall be sewn on the uniform neatly using threads that blend with the badge and uniform

Q4. True or False....the cap badge is worn centered on the forehead?

Q5. How are ankle boots laced?

## **M120 – KNOWLEDGE OF THE CANADIAN ARMED FORCES**

### **M120.01 THE ROLES OF THE CANADIAN ARMED FORCES**

In the section you will learn a little bit about the traditions and history of the Canadian Armed Forces. As part of the aims of the Cadet Program, you will get a familiarization with the CAF, as well as get to learn about your affiliated Unit, which is the 31 Combat Engineers, also known as the Elgins.

#### **THE CANADIAN FORCES INCEPTION**

The first small steps to form the Canadian Forces might be considered to be established in 1868 when Canada's Department of Militia and Defence was established with a budget of \$900 000, taking over from provincial or Canadian Militias, which were disbanded by 1869. At the time the intention was to create a militia force to support the British troops in Canada to drive out any invading force. However, in the fall of 1871 the British troops were withdrawn from Canada, leading to Canada taking moderate steps in producing its own forces. The country established two field artillery batteries to protect Quebec City and Kingston. Thus the regular army began its formation. This was expanded in 1883 when the first cavalry school corps (Royal Canadian Dragoons) was established in Quebec City followed by infantry corps (Royal Canadian Regiment) in Fredericton, Saint John and Toronto. In 1964, Defence Minister Paul Hellyer tabled a white paper in Parliament, which concluded that a unified command structure - one which amalgamated the Navy, Army and Air Forces - would better serve Canadian interests.

The modern Canadian Forces was formed on 1 February 1968 when Bill C243, The Canadian Forces Reorganization Act, became law. At this time the Canadian government merged the Canadian Army, the Royal Canadian Navy and the Royal Canadian Air Force into a unified structure. Canada remains one of the few developed countries in the world to organize its military forces like this. The integration of the Canadian Forces continued in 2005 when the CDS, General R.J. Hillier, announced an initiative to introduce a joint force management structure in the Canadian Forces to make them more "streamlined, integrated and effective."

#### **BRANCHES OF THE CANADIAN FORCES**

**Land.**The land branch of the Canadian Forces consists of three components: Regular Force; Reserve Force; and Canadian Rangers.

**Navy.**The Canadian Navy first came into being on 4 May 1910 with the passing of the Navy Bill of 1910. Currently the Canadian Navy consists of three headquarters:

- MARLANT (Maritime Forces Atlantic) – Halifax;
- MARPAC (Maritime Forces Pacific) - Esquimalt; and
- NAVRES (Naval Reserve) – Quebec City.

**Air Force.**At the outbreak of WWI Canada had no Air Force. In 1914 Canada sent the Canadian Aviation Corps, made up of three personnel and one American built Burgess-Dunne biplane to accompany the First Contingent overseas. This can be considered the first modest attempt at the formation of Canada's Air Force. Currently the Canadian Air Force consists of thirteen wings spread out across Canada.

#### **MISSION AND OBJECTIVES OF THE CF**

The mission of the Department of National Defence and the Canadian Forces is to defend Canada, its interests and its values, while contributing to international peace and security. Under Canadian Defence Policy, the Canadian Forces are called upon to fill three major roles:

1. protecting Canada;
2. defending North America in cooperation with the United States of America; and
3. contributing to peace and international security.

### **NORTH AMERICAN AEROSPACE DEFENCE COMMAND (NORAD):**

NORAD is a joint United States and Canadian organization which provides aerospace warning and aerospace control for North America. It was founded on 12 May 1958 under the name North American Air Defence Command. NORAD consists of two main parts, corresponding to its mission. Aerospace warning or Integrated Tactical Warning and Attack Assessment (ITW/AA) covers the monitoring of man-made objects in space, and the detection, validation, and warning of attack against North America by aircraft, missiles, or space vehicles. Aerospace control includes providing surveillance and control of Canadian and United States airspace. The NORAD agreement between Canada and the United States was last modified and renewed in 2006.

### **NORTH ATLANTIC TREATY ORGANIZATION (NATO):**

NATO, also called the North Atlantic Alliance, the Atlantic Alliance or the Western Alliance, is an International organization for collective security established in 1949, in support of the North Atlantic Treaty signed in Washington, DC, on 4 April 1949. Its headquarters are located in Brussels, Belgium. Its other official name is the French equivalent, l'Organisation du Traité de l'Atlantique Nord (OTAN) (English and French being the two official languages of the organization). The core of NATO is Article V of the North Atlantic Treaty, which states that, "The Parties agree that an armed attack against one or more of them in Europe or North America shall be considered an attack against them all. Consequently they agree that, if such an armed attack occurs, each of them, in exercise of the right of individual or collective self-defence recognized by Article 51 of the *Charter of the United Nations*, will assist the Party or Parties so attacked by taking forthwith, individually and in concert with the other Parties, such action as it deems necessary, including the use of armed force, to restore and maintain the security of the North Atlantic area." NATO consists of 26 member countries. Its primary function is the stability of the North Atlantic area and to safeguard the freedom of its people based on the principles of democracy, individual liberty and international law.

### **UNITED NATIONS (UN):**

The UN is an international organization that describes itself as a "global association of governments facilitating cooperation in international law, international security, economic development, and social equity." It was founded in 1945 at the signing of the United Nations Charter by 51 countries, replacing the League of Nations which was founded in 1919.

Peacekeeping operations began in 1948 with the first mission to the Middle East. Lester Pearson, prior to being elected as Canadian Prime Minister, was well recognized for his efforts building the framework for the UN and its auxiliary organizations.

### **ROLE OF EACH ELEMENT**

The CAF functions in a joint capacity for many of its international commitments. However, each element has a distinct set of responsibilities:

#### **ARMY**

- National Defence;
- Canada/US defence of North America (NORAD);
- contribution to peacekeeping missions;
- civil defence; and
- humanitarian operations including disaster relief;

#### **NAVY**

- surveillance and control of Canadian waters;
- support of Army and Air Force operations;
- support to other government departments (fisheries, search and rescue, drug enforcement, environment);
- NATO deployments; and
- humanitarian operations including disaster relief (food and medical relief, and personal and technical aide);

## **AIR FORCE**

- surveillance and control of Canadian airspace;
- worldwide airlift of CF personnel and material;
- support operations of the Army and Navy;
- support to other government departments;
- search and rescue; and
- humanitarian operations including disaster relief.

## **QUESTIONS**

ANSWER THE FOLLOWING QUESTIONS

Q1. Name one of the roles of the CF.

Q2. Where are the maritime forces located?

Q3. In what year did the Royal Canadian Air Force originate?

Q4. Who is the Affiliated Unit for 2884 West Elgin Army Cadets?

Q5. What role is common to all three elements?

Q6. Which two elements have search and rescue as one of their principal roles?

Q7. What is meant by humanitarian operations?

**M121 – PARTICIPATE AS A MEMBER OF A GROUP IN THE FIELD**

**M121.01 SELECTING PERSONAL EQUIPMENT**

**SELECTING CLOTHING**

**LAYERING SYSTEM**

The most effective way to maintain warmth and comfort in varying cold conditions is by using multiple clothing layers, rather than just one garment. Layers allow you to build a tiny microclimate that surrounds your body which can be adapted to moisture, wind, temperature and exertion levels.

**Principles of Layering**

**Temperature Control**

The temperature of air around the body will heat and cool according to the:

- amount of activity being conducted;
- ambient temperature;
- weather changes and time of day (i.e., wind, rain, snow); and
- altitude.

The simplest way to control such temperature changes of the body is through effective layering.

**Insulation**

Insulation slows the rate of heat transfer. The warmth of a garment may be considered as its ability to hold heat. The more heat it can hold over time, the more slowly it transfers heat away from the body, and the warmer the garment is. The ideal insulation would weigh next to nothing, be as thin as a tissue, and be compressible down to a tiny volume.

**MATERIAL - SYNTHETICS**

Polypropylene	<ul style="list-style-type: none"> <li>• Manmade fabric with many properties of wool</li> <li>• Relatively inexpensive</li> <li>• Same material as milk bottles</li> <li>• Base layer</li> </ul>
Polyester	<ul style="list-style-type: none"> <li>• High resilience and loft</li> <li>• Light weight</li> <li>• Clean, odourless and non-allergenic</li> <li>• Will not develop mildew</li> </ul>
Acrylic	<ul style="list-style-type: none"> <li>• Not often used</li> <li>• Good insulating properties</li> <li>• Inexpensive</li> <li>• Wears well</li> </ul>
Tyvek	<ul style="list-style-type: none"> <li>• Not very durable</li> <li>• Doesn't breath</li> </ul>
Cool-max	<ul style="list-style-type: none"> <li>• A patented polyester fabric</li> <li>• Great wicking properties</li> <li>• Base layer</li> </ul>
Gort-ex	<ul style="list-style-type: none"> <li>• Wind and water resistant</li> <li>• Limited breathability</li> <li>• Outer layer</li> </ul>
Thermax	<ul style="list-style-type: none"> <li>• Fine weave polyester</li> <li>• Dries quickly</li> <li>• Base layer</li> </ul>

## NATURAL FIBERS

Cotton	<ul style="list-style-type: none"> <li>• Absorbs and holds moisture</li> <li>• Poor material for base layer</li> <li>• Can lead to hypothermia (cotton stores moisture; when it cools, the body cools)</li> <li>• May be worn as an insulating layer for a sweater</li> </ul>
Wool	<ul style="list-style-type: none"> <li>• Doesn't absorb moisture</li> <li>• Retains insulation properties when wet</li> <li>• Best used as insulation</li> </ul>
Silk	<ul style="list-style-type: none"> <li>• Great insulating characteristics in very thin fabrics</li> <li>• Very comfortable next to skin</li> <li>• Somewhat fragile (must be laundered and dried carefully)</li> </ul>

### Types of Layers

Layering allows a person to micro adjust the immediate climate next to the body. This layering structure can be broken into three groups.

**Base Layer.** This layer actually touches the skin. During hiking, trekking, paddling or climbing, the body sweats to cool itself. As the base layer comes in direct contact with your skin, it must be a material that keeps the body warm even when wet. This layer should transport moisture away from the skin and disperse it to the air or outer layers where it can evaporate. This is known as wicking (i.e. wicking layer). The best base layer materials are synthetics, **polypropylene** and **polyester**. These materials are available in three different weights, all containing the same characteristics as listed below.

TYPES	CHARACTERISTICS
<ul style="list-style-type: none"> <li>• Light weight – suits high aerobic activity where sweat distribution is greatest.</li> <li>• Medium weight – provides moisture control and insulation for stop-and-go activities.</li> <li>• Heavy weight – best in cold conditions, or when relatively inactive.</li> </ul>	<ul style="list-style-type: none"> <li>• Light and strong</li> <li>• Absorbs very little water</li> <li>• Quick to dry</li> </ul>

**Insulating Layer.** This is the mid-layer that provides insulation and continues the transportation of moisture from the inner layer. To slow heat loss, this layer must be capable of retaining the warmth generated by the body. This is accomplished by the structure of the fibres creating small air spaces that trap molecules of warm air. Additional features, such as pit zippers and full length front zippers, allow venting. As with the inner layer, this layer should be snug but not constricting.

**Outer Layer.** The wind breaking and/or waterproof shell is the outer layer that protects a person from the elements and should allow air to circulate and excess moisture to escape. For dry conditions, a breathable (uncoated) wind shell or a smooth-surfaced soft shell may be all that is needed. If expected conditions are more severe, a waterproof (coated) rain jacket may be more effective. A shell made of a breathable and waterproof fabric protects from wind and rain, and allows water vapour to escape.



## **DRESSING THE BODY**

There are many ways to dress for most activities. Being warm and dry allows you to concentrate on, and enjoy, the activities being conducted. Insulating thickness is a determined variable based on the activities being conducted and then adjusted to fit the particular circumstance. Employing the layering method is the best way of controlling body temperature.

A choice must be made as to what clothing will best suit the environmental conditions for a particular body part. There are many parts to consider and many types of clothing to take into account.

## **SELECTING SLEEPING BAG INSULATING MATERIAL**

Sleeping bag insulation is divided into two categories, natural and synthetic.

**Natural Insulation** is usually waterfowl down – the short feathers closest to a duck’s or goose’s body that insulate the animal when in cold water. There is a variance in quality of down and the methods used to secure it in place inside the bag’s inner and outer shell. Down sleeping bags are measured according to their Fill-Power (FP) cubic inches per ounce of down. A good quality down-blend is around 550 FP. Look for a bag with good quality down with the insulation held in place by “baffles” – dividers sewn between the two shells that keep the down in place. Down is the warmest and lightest insulation that can be found in a sleeping bag; however, it loses almost all of its heat retaining ability when it gets wet and it is very difficult to dry in the field.

**Synthetic Insulation** is comprised of plastic threads that are either continuous long filaments or short staples (pieces about five centimetres long) and may be hollow. Short staples may be a mixture of thin and thick pieces. Thinner, lighter threads fill voids and trap warm air effectively while providing loft and durability. Some bags offer more insulation on the top than on the bottom. Avoid bags where the insulation is secured by sewing the two shells together creating seams where there is no insulation. Most synthetic insulation retains its insulative value when wet. Some synthetics are very light and warm – they make a better all-round choice than down for a general purpose sleeping bag. In sleeping bags, cost is often a good indicator of the quality of the bag.

## **TYPES OF SLEEPING BAGS**

The choice of a sleeping bag has a lot in common with the personal choice of outdoor clothing. It must be the right size (length and width), have the appropriate amount of insulation for the coldest expected temperature, be made of a material that breathes and doesn’t retain moisture, and have a good quality fastener (zipper). When choosing a sleeping bag, check the bag size by getting in and moving around. There should be some space for a liner and extra clothes in cold weather. Ensure to have enough room to move arms around, the ability to zip up from the inside, and enough room around the feet so that they can rest in a comfortable position.

## **SLEEPING PADS**

A sleeping pad is the foundation of a sleeping system. The pad cushions against the hard ground, and keeps a warm thermal barrier between the ground and the sleeping bag. Choose a pad that is appropriate for the activity being participated in and the weather expected. The colder the ground temperature, the more insulation needed. Pads come in several lengths and designs.

## M121.02 TRANSPORTING EQUIPMENT

### TYPES OF BACKPACKS

Backpacks come in different sizes, styles and available features. Many backpacks have been developed with specific uses in mind. They can differ greatly in their anatomy and features. Backpacks can be divided into two major categories, external frame and internal frame.

**External Frame.** These backpacks are constructed with a bag attached to a visible metal or resin frame. Some external frame packs offer a frame that adjusts in length; however, most are not adjustable. It is important to choose a frame that is the correct size. Try the backpack on and ensure the hip pads and hip belt rest snugly on your hips – the shoulder straps should connect to the harness at the same level as your shoulders. External frame packs have both advantages and disadvantages.

**Internal Frame.** These packs are constructed with a resin or aluminium frame sewn into pockets in the harness of the bag. Often the frame consists of two “stays” running vertically along the backplane. Aluminium frames are to be moulded to the shape of your back. The bag is designed to carry all your gear internally with only pockets and accessories attached to the outside. Some smaller packs may offer the option of attaching a sleeping bag stuff sack to the top or bottom. Like the external frame packs, it is important to correctly size your internal frame pack. Some models offer a range of backpack sizes and some offer adjustable or replaceable stays.

### PACKING

When preparing for a hiking exercise it is important to pack effectively. Every trip is unique and every backpack is different; however, when following certain principles in packing a backpack one can enjoy any trip with comfort and ease. To ensure a backpack is properly packed ABC’s of packing should be employed. These are: **Accessibility, Balance, and Compactness.**

**Accessibility.** When backpacking, there will always be a requirement to keep certain things accessible. In some cases it is just a matter of convenience. Keeping items one might need during the day handy will save time. Some suggested items to keep accessible are:

- lunch;
- water;
- maps;
- sunscreen;
- extra layers for warmth;
- rainwear;
- first aid kit;
- snack food;
- toilet paper;
- toilet trowel;
- camera; and
- sunglasses.

**Balance.** A heavier balanced backpack is easier to carry than a lighter unbalanced pack. If a backpack is top heavy, it will be hard to maintain balance especially when crossing obstacles and navigating sloping terrain. A backpack with too much weight at the bottom will hinder stride. The key is to pack the dense, heavy things in close to the body and at a level between the shoulder blades and the bottom of the rib cage. Items such as food, the tent, and the radio are good items to carry in mid regions of the pack.

**Compactness.** When packing gear, it is important to pack well and effectively utilize space. A compact backpack will be less awkward to carry. To take advantage of space in the pack, break large units down into smaller units. Look for dead spaces to fill with pots, pans, cups and shoes. These areas can be filled with food or clothing. Other items can be compressed down to half size using compression sacks. If the backpack has compression straps, it too can be compressed tightly.

## **PACKING CONSIDERATIONS**

- Waterproof the sleeping bag and clothes by lining the backpack with a garbage bag.
- Waterproof small items with zip-lock bags.
- Organize kit into separate stuff sacks, for example: warm underwear, socks, hat and gloves in one sack; and eating utensils, extra flashlight, batteries and toiletries in another.
- Pack food above fuel.
- Pack heavy, dense items like food close into the body.
- Odd items such as shoes can be used to fill small spaces.
- Water should be kept in an easily accessible place.
- Items like maps, first aid kit, lunch and a warm layer of clothing should be kept towards the top or outside pockets.
- Fasten all pockets and avoid letting anything hang out.
- Always protect and pad sharp edges of equipment and tools.

## **QUESTIONS**

ANSWER THE FOLLOWING QUESTIONS

Q1. What layers make up the layering system?

Q2. What is the best base layer material?

Q3. Give an example of a natural fibre.

Q4. Name and describe the ABC's to packing.

## M122 – MAP AND COMPASS

### M122.01 – TYPES OF MAPS

#### \* TOPOGRAPHICAL MAP

This type of map is commonly used by the military. The purpose of a topographical map is to present a picture of the ground as it really exists. Topographical maps show as much detail as the scale allows, generally 1:25 000, 1:50 000, or 1:250 000. **Physical features** of the ground, such as **natural features** (i.e. rivers, woods, and hills with the heights and shapes) as well **man-made features** (i.e. roads, railways, towns, villages and buildings etc.) are shown. **The names of specific features** such as towns, villages, rivers, and descriptive names of general features such as railways, fords and post offices are also found on topographical maps.

#### \* ORIENTEERING MAP

Through the International Orienteering Federation (IOF), specific rules and standards have been set for the production of orienteering maps, including colour, symbols, and scales. They are much more detailed than regular topographic maps, both with reference to vegetation and landforms.

#### \* STREET AND ROAD MAP

Street and road maps are designed to assist commuters and tourists to locate key site such as roads and highways, police stations, fire halls, hospitals, schools, parks and more.

#### \* RELIEF MAP

Relief maps are a three dimensional representation, usually of terrain. The terrain elevation is usually exaggerated by a factor between five and ten. This helps to visually recognise the terrain features.

#### DIGITAL MAP

Digital maps, such as those found on computer programs and when using a GPS, are useful as reference tools as they are updated regularly. This allows for a generally more accurate reference.

#### POLITICAL MAP

Political maps show countries, provinces or other political borders (e.g. globes and atlases).

#### STATISTICAL MAP

Statistical maps show statistical information such as the production levels of crops or minerals across a country.

#### OUTLINE MAP

Outline maps show only borders, rivers, coastlines, etc.

#### AIR PHOTO MAP

Air photomaps are actual pictures used in reconnaissance or to create many of the maps listed.

## M122.02 MARGINAL INFORMATION

### Conventional Signs

The information in this teaching point is presented to provide the instructor with background knowledge of conventional signs. A number of symbols are used to indicate an object or item of detail that cannot be shown either by outline or by a line symbol. Most have been established through long usage and standardization agreements. The meaning of most symbols is obvious. If there is doubt however, consult the table of conventional symbols located on every map. Located on the back of most maps you will find many additional conventional signs. Map reading not only involves the ability to interpret the symbols shown on the map and to understand the information given in pictorial or written form, but it also involves a true understanding of the ground portrayed and an appreciation of the reliability and value of the particular map being used. Where the symbol may have more than one meaning, the sign or symbol will be accompanied by a descriptive word (e.g. tank or tower).

### Man-made Features by Colour





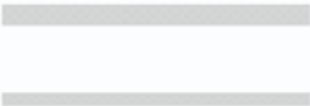

**Red** is used to identify paved roads and highway numbers. Red is also used to shade in areas of urban development.

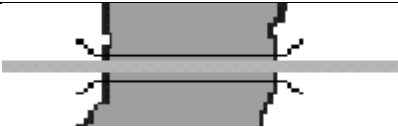

Road paved surface 2 lane; 1 lane (red)	
--	--

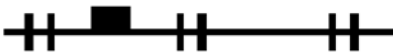
**Orange** is used to represent unpaved roads.

Road loose surface 2 lane; 1 lane (orange)	
---	---



**Black** is used for cultural features, toponyms (place names), some symbols and precise elevations.

Tunnel	
Railway – single track	
Railway – multi track with station	
Road track	
School	
Fire Department	
Police Station	Police 

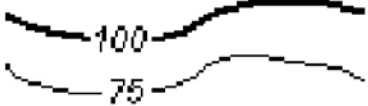

Church	
Buildings	

**Natural Features by Colour**

**Brown** is used for contour lines, contour elevations, spot elevations, sand, cliffs, and other geological features.

Contours (dark)	
Cliff (dark)	
Sand	

**Blue** is used for water or permanent ice features (i.e., rivers, lakes, swamps and ice fields), names of water features and the grid lines.

River with arrow indicating direction of flow	
Rapids	

**Green**, which is used for vegetation features (i.e., woods, orchards and vineyards).

Orchard	
---------	--

**Additional Features by Colour**

**Grey** is used for the legend of conventional signs on the back of the map.

**Purple** is used for updates that are made over top of the original map information.

## M122.03 CONTOUR LINES

### SLOPES

The distance between contour lines on the map will indicate to you the type of slope on the ground.

**Steep Slope.**When the contour lines are spaced closely together there is less distance to travel to gain or lose elevation (see Figure 11-3-1).

**Gentle Slope.**When the contour lines are further apart there is a greater distance to travel to gain or lose elevation (see Figure 11-3-1).

**Uniform Slope.**When the contours are an equal distance apart. The slope remains constant in its decline, whether steep or gentle (see Figure 11-3-1).

**Spurs.**A contour feature that extends out from a slope (see Figure 11-3-2).

**Re-entrants.**A contour feature that cuts back into a slope (see Figure 11-3-2).

**Concave Slope.**When the spacing of the contours gets further apart at the bottom. The middle of the slope seems to depress inward – appearing concave (see Figure 11-3-3).

**Convex Slope.**When the spacing of contours down a slope gets close together at the bottom. The middle of the slope seems to bulge outward – appearing convex (see Figure 11-3-4).

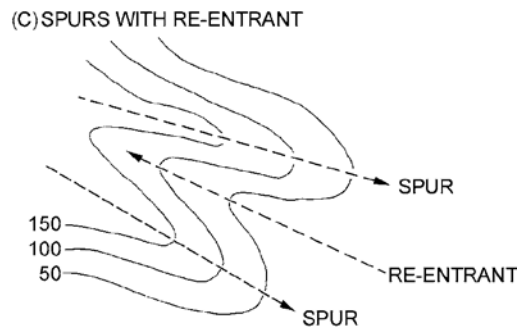
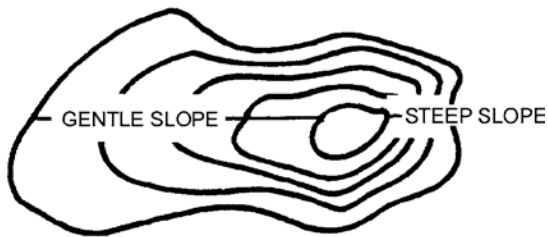

(E) CONCAVE SLOPE  
(STEEPER AT TOP THAN LOWER DOWN)

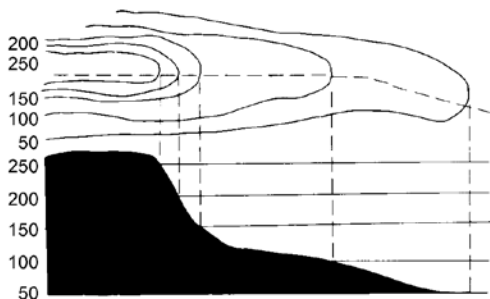

(F) CONVEX SLOPE  
(STEEPER AT LOWER END)

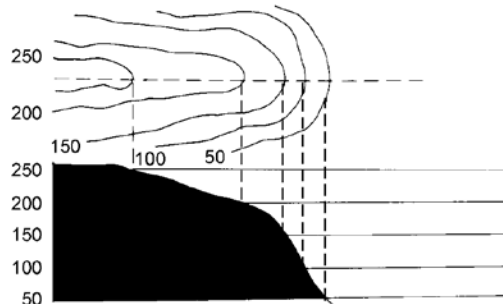

ACTIVITY – CONTOUR LINES

Match the contour diagram on the left to the applicable depiction of a landform on the right.



1

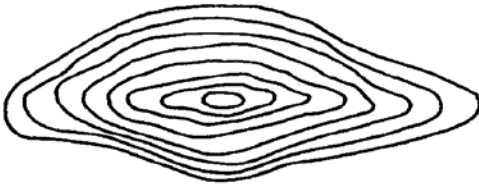

2

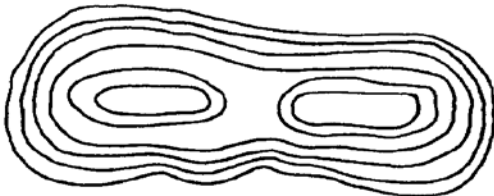

3



4



5

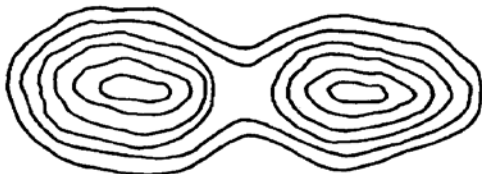

6



A



B



C



D



E



F

1. \_\_\_\_\_

2. \_\_\_\_\_

3. \_\_\_\_\_

4. \_\_\_\_\_

5. \_\_\_\_\_

6. \_\_\_\_\_



## M122.05 - GRID REFERENCE

### USE OF GRID SYSTEM

The grid system is a rectangular network of intersecting vertical and horizontal blue lines superimposed on a topographical map. Maps are normally printed so that north is at the top of the sheet when the writing is the right way up. The lines of the grid system are drawn evenly spaced so that one set of lines run north to south (vertically) and the second set of lines run east to west (horizontally). These lines are assigned a sequential number starting in the bottom left corner. The intersecting grid lines at the lower left corner designate a grid square.

### EASTINGS

Because the vertical lines are numbered from east to west, they are called **eastings**. Eastings are a series of parallel lines plotted as an overlay to the map sheet, with a two-digit number at the top and bottom end of each line in the margins.

### NORTHINGS

Because the horizontal lines are numbered from the equator toward the north, they are called **northings**. Northings are a series of parallel lines plotted as an overlay to the map sheet, with a two-digit number at the left and right end of each line in the margins.

### GRID REFERENCE

The military traditionally identify grid lines by stating the two-digit number of each grid line. When a location is identified using the grid system it is called a "Grid Reference" (GR). When giving a GR to a square, the reference is always to the southwest (bottom left) corner of the square. GRs are always given with the easting value first, followed by the northing value.

### FOUR-FIGURE GR

A four-figure GR is used to identify a specific 1000 metre by 1000 metres grid square. It will have four numerical digits derived from the numbers assigned to the eastings on the X-axis, and the northings on the Y-axis, where the grid lines intersect at the bottom left corner of the grid square.

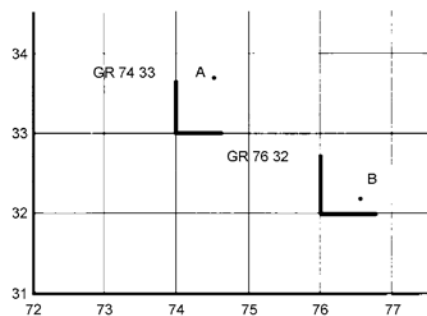

### ACCURACY OF A GRID REFERENCE

The accuracy of a four-figure GR on a map sheet with a 1:50 000 scale is 1000 metres. When a more precise location is required, a six-figure GR is used which is accurate to 100 metres.

### SIX-FIGURE GR

A six-figure GR is used to determine a more accurate location within a specific grid square. It is necessary to break up the grid square shown on the map into 100 subdivisions (10 in each direction). By creating an imaginary grid inside a grid square, we can use the same principles of the four-figure grid reference to make a more accurate statement of location. Each small easting and northing is numbered 1 to 9, from west to east and from south to north respectively. This imaginary grid inside a square can be estimated, or you can measure accurately using a tool called a "romer".

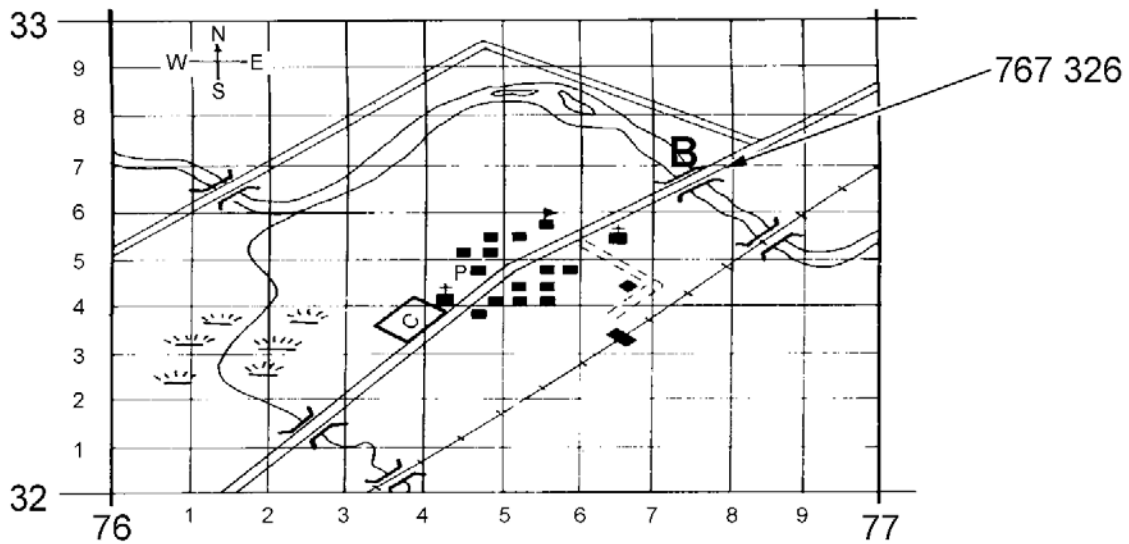

### ROMER

A romer is used to accurately measure a six-figure GR. Using a romer provides a more accurate GR, and can be used in place of estimating.

### TYPES OF ROMERS

Romers for 1:25 000 and 1:50 000 scales in metres are included on the base plate of the compass and are also found on the Protractor C2. If these romers are not available, one can be easily made from a clean piece of paper with a square edge.



Romer on Compass

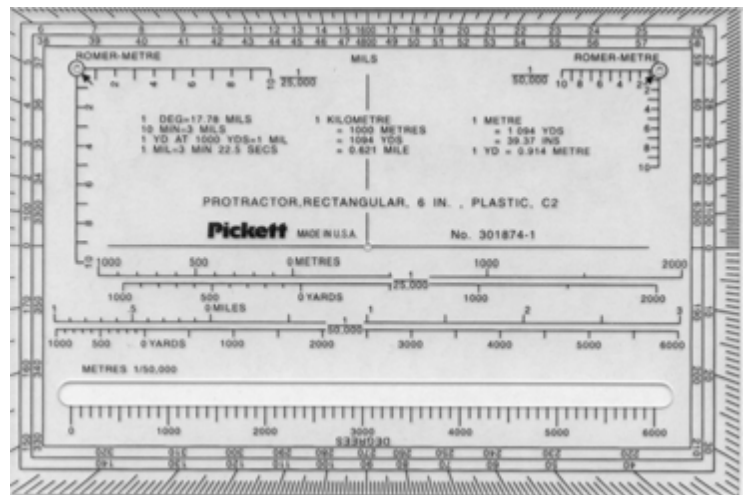

Protractor

## DETERMINE 6 FIGURE GRID REFERENCE

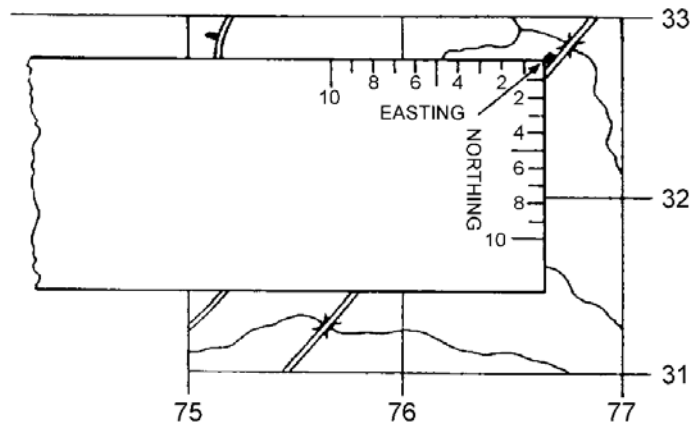

A six-figure grid reference can be determined using a constructed romer by following these steps:

- place the corner of the constructed romer on the grid square;
- move the constructed romer **IN** the number of tenths required to align the romer directly below the conventional sign, or the location for which the GR is being determined;
- move the constructed romer **UP** the number of tenths required for the corner of the romer to be positioned on the conventional sign, or location for which the GR is being determined;
- read the value along the X-axis of the romer where it crosses the easting of the grid square (the value at this intersection becomes the third digit of the six-figure GR); and
- read the value along the Y-axis of the romer where it crosses the northing of the grid square (the value at this intersection becomes the sixth digit of the six-figure GR).

ACTIVITY

Find the 4 figure Grid Reference for the following

**4 Figure Grid Reference**

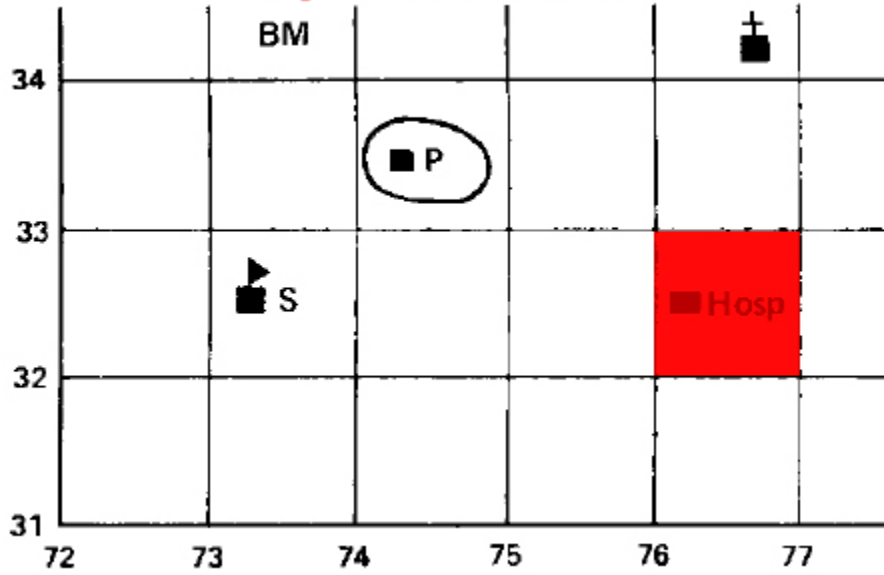

- School \_\_\_\_\_
- Church \_\_\_\_\_
- Hospital \_\_\_\_\_

**ACTIVITY**

Find the 6 figure Grid Reference

How to find a  
six figure Grid  
Reference

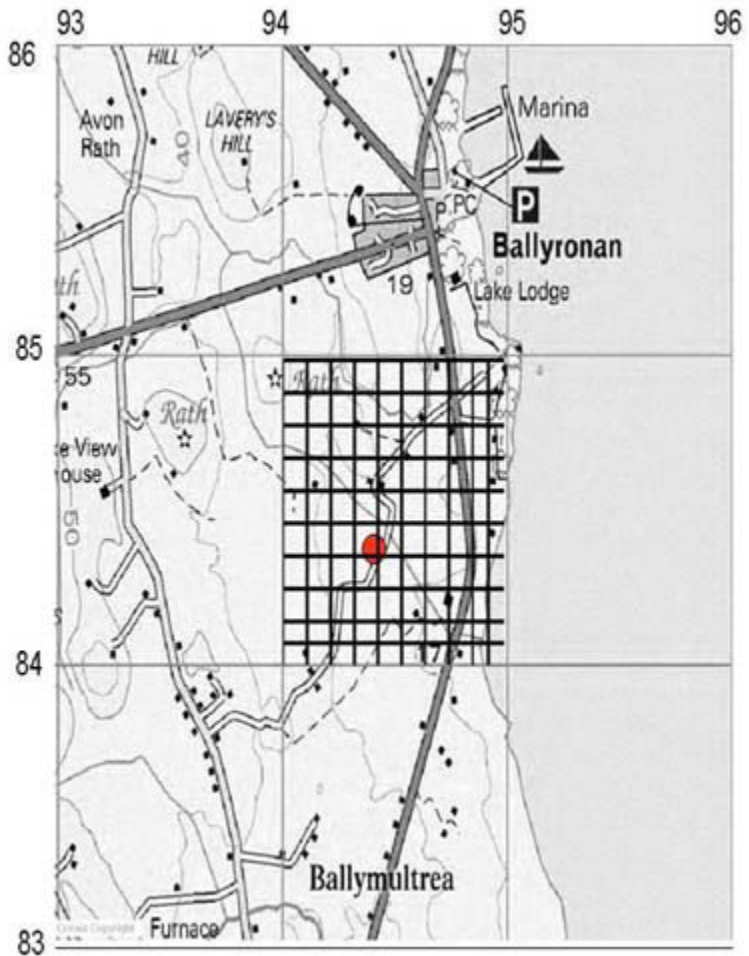

The red spot can be found at Grid Reference H 944 844

What is the GR for the two roads intersecting within the square with the romer?

What is located at GR 941 846?











## EVALUATION SHEETS

The following pages are for evaluation pages. These need to be submitted to assessor when being monitored on certain skills. They will be filed in your training file once completed. They are only to be filled out by supervising staff at time of assessment.

## GREEN STAR PROGRAM QUALIFICATION RECORD

Cadet's Name: \_\_\_\_\_

Topic	PO	Performance Statement	PO ASSESSMENT		CO WAIVER
			PARTICIPATED	DID NOT PARTICIPATE	
Citizenship	101	Participate in Citizenship Activities			
Community Service	102	Perform Community Service			
Leadership	103	Participate in Team Building Activities			
Personal Fitness and Healthy Living	104	Develop a Personal Activity Plan			
Recreational Sports	105	Participate in Recreational Sports			
Air Rifle Marksmanship	106	Fire the Cadet Air Rifle			
General Cadet Knowledge	107	Serve in an Army Cadet Corps			
Drill	108	Participate in an Annual Ceremonial Review (ACR) Parade			
CF Familiarization	120	Demonstrate Knowledge of the Organization and Traditions of the Canadian Forces			
Field Training	121	Participate as a Member of a Group During a Weekend Bivouac Exercise			
Navigation	122	Identify Location Using a Map			
Trekking	123	Participate in a Day Hike			
PYSR					

**Green Star Program  
Qualification Achieved**

**YES**

**NO**

Trg O's Signature: \_\_\_\_\_ Date: \_\_\_\_\_

CADET AIR RIFLE HANDLING TEST

Name: \_\_\_\_\_

Assessed By: \_\_\_\_\_

<b>Individual Safety Precautions</b>	
Did the cadet:	
1. Ensure the bolt was fully open and to the rear	
2. Ensure the safety catch was in the ON position	
3. Ensure the pump lever was partially open (2 to 3 in.)	
4. Ensure the safety rod was inserted in the barrel and visible in the feed track	
<b>Loading Procedure</b>	
Did the cadet:	
5. Ensure the safety catch was in the ON position	
6. Pump the air rifle, observing a 3-second pause	
7. Open the bolt (if necessary)	
8. Load a pellet (flat end forward)	
9. Close the bolt	
<b>Firing Procedure</b>	
Did the cadet:	
10. Place the safety catch in the OFF position	
11. Aim at the target	
12. Squeeze the trigger	
13. Open the bolt	
14. Place the safety in the ON position	
15. Partially open the pumping handle	
16. Lay down the air rifle	

<b>Unloading Procedure</b>	
Did the cadet:	
17. Open the bolt (without loading a pellet)	
18. Pump the air rifle, observing a 3-second pause	
19. Close the bolt (without loading a pellet)	
20. Place the safety in the OFF position	
21. Aim the rifle at the target	
22. Fire the action	
23. Place the safety catch in the ON position	
<b>Prepare for Inspection</b>	
Did the cadet:	
24. Open the bolt	
25. Open the pump lever slightly	
26. Place the rifle on their shoulder, muzzle pointed down range	
27. Wait to be cleared by the RSO	
<b>Cadet Air Rifle Handling Test Result</b>	
Was the cadet:	
Successful (S)/Unsuccessful (U)	

**Notes:**

1. Steps shall be conducted sequentially.
2. Cadets may be retested until they are successful.

RSO's Signature: \_\_\_\_\_

Date: \_\_\_\_\_

DRILL EVALUATION

DRILL MOVEMENT	COMPLETED	
	YES	NO
<b>ADOPT THE POSITIONS OF ATTENTION, STAND AT EASE AND STAND EASY</b>		
<b>EXECUTE A SALUTE AT THE HALT WITHOUT ARMS</b>		
<b>EXECUTE TURNS AT THE HALT</b>		
<b>CLOSE TO THE RIGHT AND LEFT</b>		
<b>EXECUTE PACES FORWARD AND TO THE REAR</b>		
<b>EXECUTE THE MOVEMENTS REQUIRED FOR A RIGHT DRESS</b>		
<b>EXECUTE AN OPEN ORDER AND CLOSE ORDER MARCH</b>		
<b>MARCH AND HALT IN QUICK TIME</b>		
<b>EXECUTE MARKING TIME, FORWARD, AND HALTING IN QUICK TIME</b>		
<b>EXECUTE A SALUTE ON THE MARCH</b>		

COMPLETED                      YES                      NO

TRG O SIGNATURE \_\_\_\_\_

DATE \_\_\_\_\_

BIVUOAC EVALUATIONS

TASK TO BE COMPLETED	COMPLETED	
	YES	NO
TIE THUMB KNOT		
TIE REEF KNOT		
TIE FIGURE EIGHT KNOT		
TIE DOUBLE FIGURE EIGHT KNOT		
TIE CLOVE HITCH		
TIE HALF HITCH		